

Outer Dimension

Note

1. This bracket can be used for the model RLE, RU, RS, RHE(B), RKE(B), RH(B)-A, RK(B)-A, SKHE(B), SKH(B)-A, SKH-EA, RLR(-P), KP-A, SKP-A, SKC-A, SKL(A/B/S)-A, SKR-A, HKM-A, RV-A, KG, KES(B), KJ(S/B/T), RK(T/PV), RT, LG(E/H), PS(F/X), KX, PES-A, PEW-A(B), KHE, KPE-A, KLE, LKEH, PSE, LFH, XP(E) and XM(E).
2. The following requirements are necessary for proper installation.
 - Install where vibration is not present.
 - Install on a strong surface.
 - Install on a level surface.
3. When using the Mounting Rubber (model SZ-200A, SZ-210) in addition to this product, the IP rating is not set to IP55.
4. Such as the model SKL-A, HKM-A, XM, and etc, because the taking off of the globe is difficult, it should be installed with reference to "Installation example".
5. Mass : 0.66kg±10%

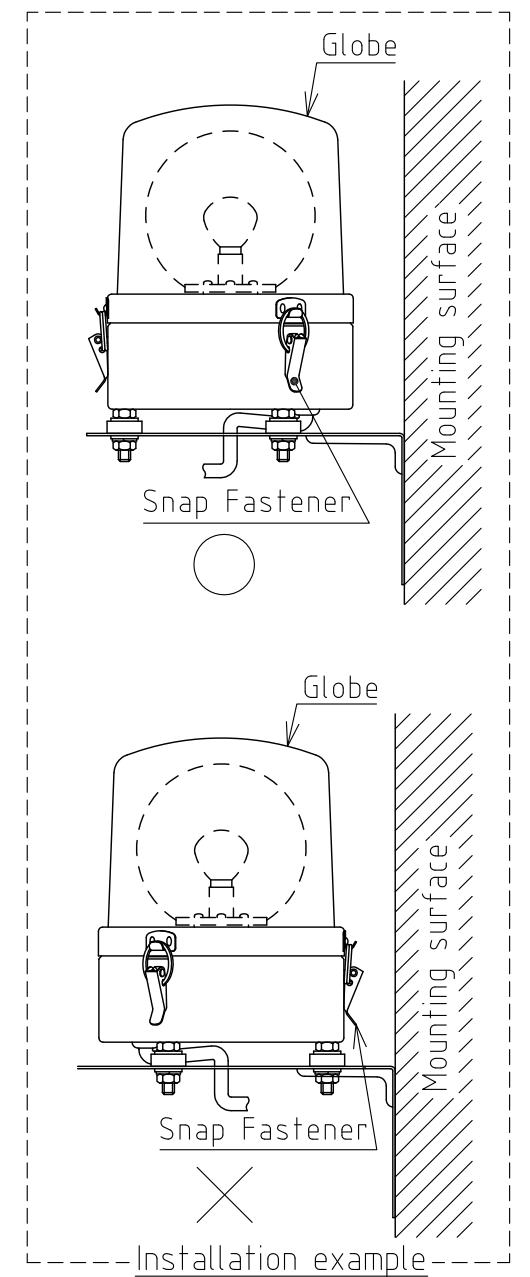

Material : SECC-P(Electro-galvanized Iron), t1.6
 Treatment : Polyester-type Powdered Coating (Mansell No.(Approximation):5Y8/1)

製品仕様書
 Specifications
 株式会社 パトライト
 PATLITE Corporation
 SZ-008-W18B